

Functions of a complex variable

Derivative: If $w = f(z)$ where z and w are complex numbers, the derivative $\frac{dw}{dz}$ at z_0 is

$$f'(z_0) = \lim_{z \rightarrow z_0} \left[\frac{f(z) - f(z_0)}{z - z_0} \right]$$

provided that the limit exists as $z \rightarrow z_0$ along any path. If $f(z)$ has a derivative at a point z_0 and at all points in some neighbourhood of z_0 then $f(z)$ is said to be **analytic** at z_0 . If $f(z)$ is analytic at all points in an (open) region R then $f(z)$ is said to be **analytic** in R .

Cauchy-Riemann equations: If $z = x + jy$ and $w = f(z) = u(x, y) + jv(x, y)$ where x, y, u and v are real variables, and $f(z)$ is analytic in some region R of the z plane, then the **Cauchy-Riemann equations** hold throughout R :

$$\frac{\partial u}{\partial x} = \frac{\partial v}{\partial y} \quad \frac{\partial u}{\partial y} = -\frac{\partial v}{\partial x}$$

If these partial derivatives are continuous within R , the Cauchy-Riemann equations are sufficient conditions to ensure $f(z)$ is analytic. Furthermore, $f'(z) = \frac{\partial u}{\partial x} + i \frac{\partial v}{\partial x}$.

Singularities: If $f(z)$ fails to be analytic at a point z_0 but is analytic at some point in every neighbourhood of z_0 then z_0 is called a **singular point** of $f(z)$.

Laurent series: If $f(z)$ is analytic on concentric circles C_1 and C_2 of radii r_1 and r_2 , centred at z_0 , and also analytic throughout the annular region between the circles, then for each point z within the annulus, $f(z)$ may be represented by the Laurent series

$$f(z) = \sum_{n=-\infty}^{\infty} c_n (z - z_0)^n$$

in which c_n are complex constants. The series may be written

$$f(z) = \sum_{n=-\infty}^{-1} c_n (z - z_0)^n + \sum_{n=0}^{\infty} c_n (z - z_0)^n$$

Poles: The first sum on the right is the **principal part**. If there are only a finite number of terms in the principal part e.g.

$$f(z) = \frac{c_{-m}}{(z - z_0)^m} + \dots + \frac{c_{-1}}{(z - z_0)} + c_0 + c_1(z - z_0) + \dots + c_m(z - z_0)^m + \dots$$

in which $c_{-m} \neq 0$, then $f(z)$ has a singularity called a **pole of order m** at $z = z_0$. A pole of order 1 is called a **simple pole**. If there are infinitely many terms in the principal part, z_0 is called an **isolated essential singularity**. If the principal part is zero, then $f(z)$ has a **removable singularity** at $z = z_0$ and the Laurent series reduces to a Taylor series.

Residues: If $f(z)$ has a pole at $z = z_0$ then the coefficient, c_{-1} , of $\frac{1}{z - z_0}$ in the Laurent expansion is called the **residue** of $f(z)$ at $z = z_0$. The residue at a pole of order m is given by:

$$\frac{1}{(m - 1)!} \lim_{z \rightarrow z_0} \left\{ \frac{d^{m-1}}{dz^{m-1}} [(z - z_0)^m f(z)] \right\}$$

When evaluating the integrals which follow, the curve C is traversed in an anticlockwise sense.

Cauchy's theorem: If $f(z)$ is analytic within and on a simple closed curve C then $\oint_C f(z) dz = 0$.

Cauchy's integral formula: If $f(z)$ is analytic within and on a simple closed curve C , and if z_0 is any point within C then

$$\oint_C \frac{f(z)}{z - z_0} dz = 2\pi j f(z_0)$$

Further

$$\oint_C \frac{f(z)}{(z - z_0)^{n+1}} dz = \frac{2\pi j}{n!} f^{(n)}(z_0)$$

The residue theorem: If $f(z)$ is analytic within and on a simple closed curve C apart from a finite number of poles inside C , then

$$\oint_C f(z) dz = 2\pi j \times [\text{sum of residues of } f(z) \text{ at the poles inside } C]$$

Eigenvalues & Eigenvectors

An **eigenvector** of a square matrix A is a non-zero column vector X such that $AX = \lambda X$ where λ , (a scalar), is the corresponding **eigenvalue**. The eigenvalues are found by solving the **characteristic equation**

$$\det(A - \lambda I) = 0$$

An $n \times n$ symmetric matrix A with real elements has only real eigenvalues and n independent eigenvectors. The eigenvectors corresponding to distinct eigenvalues of a real symmetric matrix are orthogonal.

The **modal matrix** corresponding to the $n \times n$ square matrix A is an $n \times n$ square matrix P whose columns are the eigenvectors of A . If n independent eigenvectors are used to form P then $P^{-1}AP$ is a diagonal matrix in which the diagonal entries are the eigenvalues of A taken in the same order that the eigenvectors were taken to form P .

For the help you need to support your course

more Facts & Formulas

mathcentre is a project offering students and staff free resources to support the transition from school mathematics to university mathematics in a range of disciplines.

www.mathcentre.ac.uk



This leaflet has been produced in conjunction with and is distributed by the Higher Education Academy Maths, Stats & OR Network.



For more copies contact the Network at info@mathstore.ac.uk

Vector Calculus

$$\text{grad} \equiv \nabla \quad \text{div} \equiv \nabla \cdot \quad \text{curl} \equiv \nabla \times$$

$$\nabla \equiv \mathbf{i} \frac{\partial}{\partial x} + \mathbf{j} \frac{\partial}{\partial y} + \mathbf{k} \frac{\partial}{\partial z}$$

$$\text{Laplacian} \equiv \nabla^2 \equiv \text{div}(\text{grad}) \equiv \nabla \cdot \nabla \equiv \frac{\partial^2}{\partial x^2} + \frac{\partial^2}{\partial y^2} + \frac{\partial^2}{\partial z^2}$$

If $\Phi(x, y, z)$ is a scalar field and $\mathbf{v}(x, y, z) = v_1\mathbf{i} + v_2\mathbf{j} + v_3\mathbf{k}$ is a vector field

$$\text{grad } \Phi = \nabla \Phi = \frac{\partial \Phi}{\partial x} \mathbf{i} + \frac{\partial \Phi}{\partial y} \mathbf{j} + \frac{\partial \Phi}{\partial z} \mathbf{k} \quad \text{a vector.}$$

$$\text{div } \mathbf{v} = \nabla \cdot \mathbf{v} = \frac{\partial v_1}{\partial x} + \frac{\partial v_2}{\partial y} + \frac{\partial v_3}{\partial z} \quad \text{a scalar.}$$

$$\text{curl } \mathbf{v} = \nabla \times \mathbf{v} = \begin{vmatrix} \mathbf{i} & \mathbf{j} & \mathbf{k} \\ \frac{\partial}{\partial x} & \frac{\partial}{\partial y} & \frac{\partial}{\partial z} \\ v_1 & v_2 & v_3 \end{vmatrix} \quad \text{a vector.}$$

$$\nabla^2 \Phi = \frac{\partial^2 \Phi}{\partial x^2} + \frac{\partial^2 \Phi}{\partial y^2} + \frac{\partial^2 \Phi}{\partial z^2}.$$

$$\nabla^2 \mathbf{v} = \left(\frac{\partial^2}{\partial x^2} + \frac{\partial^2}{\partial y^2} + \frac{\partial^2}{\partial z^2} \right) (v_1\mathbf{i} + v_2\mathbf{j} + v_3\mathbf{k}).$$

Vector calculus identities:

$$\text{grad}(\Phi\psi) = \Phi \text{grad } \psi + \psi \text{grad } \Phi$$

$$\text{div}(\Phi\mathbf{a}) = \Phi \text{div } \mathbf{a} + \mathbf{a} \cdot \text{grad } \Phi$$

$$\text{curl}(\Phi\mathbf{a}) = \Phi \text{curl } \mathbf{a} + \text{grad } \Phi \times \mathbf{a}$$

$$\text{curl grad } \Phi = \mathbf{0}, \quad \text{div curl } \mathbf{a} = 0$$

$$\text{curl curl } \mathbf{a} = \text{grad div } \mathbf{a} - \nabla^2 \mathbf{a}$$

$$\text{grad}(\mathbf{a} \cdot \mathbf{b}) = (\mathbf{b} \cdot \text{grad})\mathbf{a} + (\mathbf{a} \cdot \text{grad})\mathbf{b} + \mathbf{b} \times \text{curl } \mathbf{a} + \mathbf{a} \times \text{curl } \mathbf{b}$$

$$\text{div}(\mathbf{a} \times \mathbf{b}) = \mathbf{b} \cdot \text{curl } \mathbf{a} - \mathbf{a} \cdot \text{curl } \mathbf{b}$$

$$\text{curl}(\mathbf{a} \times \mathbf{b}) = (\mathbf{b} \cdot \text{grad})\mathbf{a} - (\mathbf{a} \cdot \text{grad})\mathbf{b} + \mathbf{a} \text{div } \mathbf{b} - \mathbf{b} \text{div } \mathbf{a}$$

Green's theorem in the plane:

$$\oint_C (Pdx + Qdy) = \int_R \left(\frac{\partial Q}{\partial x} - \frac{\partial P}{\partial y} \right) dx dy.$$

Stokes' theorem:

$$\oint_C \mathbf{v} \cdot d\mathbf{r} = \int_S \text{curl } \mathbf{v} \cdot d\mathbf{S}.$$

The divergence theorem:

$$\oint_S \mathbf{v} \cdot d\mathbf{S} = \int_V \text{div } \mathbf{v} dV.$$

Spherical polar coordinates

The diagram shows spherical polar coordinates (R, θ, ϕ) .

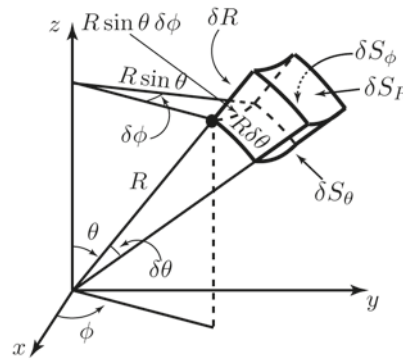

$$\left. \begin{aligned} x &= R \sin \theta \cos \phi \\ y &= R \sin \theta \sin \phi \\ z &= R \cos \theta \end{aligned} \right\} \begin{aligned} R &\geq 0 \\ 0 &\leq \theta \leq \pi \\ 0 &\leq \phi < 2\pi \end{aligned}$$

If $\mathbf{v} = v_R \hat{\mathbf{e}}_R + v_\theta \hat{\mathbf{e}}_\theta + v_\phi \hat{\mathbf{e}}_\phi$:

$$\nabla \Phi = \frac{\partial \Phi}{\partial R} \hat{\mathbf{e}}_R + \frac{1}{R} \frac{\partial \Phi}{\partial \theta} \hat{\mathbf{e}}_\theta + \frac{1}{R \sin \theta} \frac{\partial \Phi}{\partial \phi} \hat{\mathbf{e}}_\phi.$$

$$\nabla \cdot \mathbf{v} = \frac{1}{R^2} \frac{\partial}{\partial R} (R^2 v_R) + \frac{1}{R \sin \theta} \frac{\partial}{\partial \theta} (v_\theta \sin \theta) + \frac{1}{R \sin \theta} \frac{\partial}{\partial \phi} (v_\phi).$$

$$\nabla \times \mathbf{v} = \frac{1}{R^2 \sin \theta} \begin{vmatrix} \hat{\mathbf{e}}_R & R \hat{\mathbf{e}}_\theta & R \sin \theta \hat{\mathbf{e}}_\phi \\ \frac{\partial}{\partial R} & \frac{\partial}{\partial \theta} & \frac{\partial}{\partial \phi} \\ v_R & R v_\theta & R \sin \theta v_\phi \end{vmatrix}.$$

$$\nabla^2 \Phi = \frac{1}{R^2} \frac{\partial}{\partial R} \left(R^2 \frac{\partial \Phi}{\partial R} \right) + \frac{1}{R^2 \sin \theta} \frac{\partial}{\partial \theta} \left(\sin \theta \frac{\partial \Phi}{\partial \theta} \right) + \frac{1}{R^2 \sin^2 \theta} \frac{\partial^2 \Phi}{\partial \phi^2}.$$

Volume element: $\delta V = R^2 \sin \theta \delta R \delta \theta \delta \phi$.

Surface elements:

$$\delta S_R = R^2 \sin \theta \delta \theta \delta \phi,$$

$$\delta S_\theta = R \sin \theta \delta R \delta \phi,$$

$$\delta S_\phi = R \delta R \delta \theta.$$

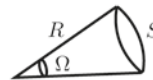

Solid angles: Consider part of a sphere of radius R . If the area cut off on the surface is S , the **solid angle** at the centre is $\Omega = \frac{S}{R^2}$ steradians. The solid angle at the apex of a cone of semi-vertical angle θ is $\Omega = 2\pi(1 - \cos \theta)$.

Cylindrical polar coordinates

The diagram shows cylindrical polar coordinates (r, ϕ, z) .

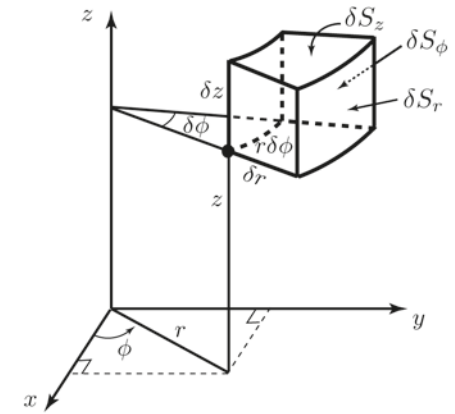

$$\left. \begin{aligned} x &= r \cos \phi \\ y &= r \sin \phi \\ z &= z \end{aligned} \right\} \begin{aligned} r &\geq 0 \\ 0 &\leq \phi < 2\pi \\ -\infty &< z < \infty \end{aligned}$$

If $\mathbf{v} = v_r \hat{\mathbf{e}}_r + v_\phi \hat{\mathbf{e}}_\phi + v_z \hat{\mathbf{e}}_z$:

$$\nabla \Phi = \frac{\partial \Phi}{\partial r} \hat{\mathbf{e}}_r + \frac{1}{r} \frac{\partial \Phi}{\partial \phi} \hat{\mathbf{e}}_\phi + \frac{\partial \Phi}{\partial z} \hat{\mathbf{e}}_z.$$

$$\nabla \cdot \mathbf{v} = \frac{1}{r} \frac{\partial}{\partial r} (r v_r) + \frac{1}{r} \frac{\partial}{\partial \phi} (v_\phi) + \frac{\partial v_z}{\partial z}.$$

$$\nabla \times \mathbf{v} = \frac{1}{r} \begin{vmatrix} \hat{\mathbf{e}}_r & r \hat{\mathbf{e}}_\phi & \hat{\mathbf{e}}_z \\ \frac{\partial}{\partial r} & \frac{\partial}{\partial \phi} & \frac{\partial}{\partial z} \\ v_r & r v_\phi & v_z \end{vmatrix}.$$

$$\nabla^2 \Phi = \frac{1}{r} \frac{\partial}{\partial r} \left(r \frac{\partial \Phi}{\partial r} \right) + \frac{1}{r^2} \frac{\partial^2 \Phi}{\partial \phi^2} + \frac{\partial^2 \Phi}{\partial z^2}.$$

Volume element: $\delta V = r \delta r \delta \phi \delta z$.

Surface elements:

$$\delta S_r = r \delta \phi \delta z,$$

$$\delta S_\phi = \delta r \delta z,$$

$$\delta S_z = r \delta r \delta \phi.$$

Written by Tony Croft & Joe Ward
for the Mathematics Learning Support Centre
at Loughborough University

Typesetting and artwork by the authors

© 1999, © 2001



Fourier Series

Fourier series:

If $f(t)$ is periodic with period T its Fourier series is given by

$$f(t) = \frac{a_0}{2} + \sum_{n=1}^{\infty} \left(a_n \cos \frac{2n\pi t}{T} + b_n \sin \frac{2n\pi t}{T} \right)$$

or equivalently, if $\omega = 2\pi/T$,

$$f(t) = \frac{a_0}{2} + \sum_{n=1}^{\infty} (a_n \cos n\omega t + b_n \sin n\omega t).$$

a_n and b_n are called the **Fourier coefficients**, given by

$$a_n = \frac{2}{T} \int_d^{d+T} f(t) \cos \frac{2n\pi t}{T} dt, \quad \text{for } n = 0, 1, 2, 3 \dots$$

$$b_n = \frac{2}{T} \int_d^{d+T} f(t) \sin \frac{2n\pi t}{T} dt, \quad \text{for } n = 1, 2, 3 \dots$$

where d can be chosen to have any value.

If $f(t)$ is odd, $a_n \equiv 0$ and $f(t) = \sum_{n=1}^{\infty} b_n \sin n\omega t$.

If $f(t)$ is even, $b_n \equiv 0$ and $f(t) = \frac{a_0}{2} + \sum_{n=1}^{\infty} a_n \cos n\omega t$.

Parseval's theorem:

$$\frac{2}{T} \int_0^T (f(t))^2 dt = \frac{1}{2} a_0^2 + \sum_{n=1}^{\infty} (a_n^2 + b_n^2).$$

Complex form:

$$f(t) = \sum_{n=-\infty}^{\infty} c_n e^{j2n\pi t/T}, \quad c_n = \frac{1}{T} \int_{-T/2}^{T/2} f(t) e^{-j2n\pi t/T} dt.$$

Half-range sine series: Given $f(t)$ for $0 < t < \frac{T}{2}$, its odd periodic extension has period T and Fourier series given by

$$f(t) = \sum_{n=1}^{\infty} b_n \sin \frac{2n\pi t}{T}.$$

$$b_n = \frac{4}{T} \int_0^{T/2} f(t) \sin \frac{2n\pi t}{T} dt \quad \text{for } n = 1, 2, 3 \dots$$

Half-range cosine series: Given $f(t)$ for $0 < t < \frac{T}{2}$, its even periodic extension has period T and Fourier series given by

$$f(t) = \frac{a_0}{2} + \sum_{n=1}^{\infty} a_n \cos \frac{2n\pi t}{T}.$$

$$a_n = \frac{4}{T} \int_0^{T/2} f(t) \cos \frac{2n\pi t}{T} dt \quad \text{for } n = 0, 1, 2, 3 \dots$$

The Fourier transform

The **Fourier transform** of $f(t)$ is $F(\omega)$ defined by

$$\mathcal{F}\{f(t)\} = \int_{-\infty}^{\infty} f(t) e^{-j\omega t} dt = F(\omega).$$

The **inverse Fourier transform** is given by

$$\mathcal{F}^{-1}\{F(\omega)\} = \frac{1}{2\pi} \int_{-\infty}^{\infty} F(\omega) e^{j\omega t} d\omega = f(t).$$

function $f(t)$	Fourier transform $F(\omega)$
$Au(t)e^{-\alpha t}, \alpha > 0$	$\frac{A}{\alpha + j\omega}$
$\begin{cases} 1 & -\alpha \leq t \leq \alpha \\ 0 & \text{otherwise} \end{cases}$	$\frac{2 \sin \omega \alpha}{\omega}$
A constant	$2\pi A \delta(\omega)$
$u(t)A$	$A \left(\pi \delta(\omega) - \frac{j}{\omega} \right)$
$\delta(t)$	1
$\delta(t - a)$	$e^{-j\omega a}$
$\cos at$	$\pi (\delta(\omega + a) + \delta(\omega - a))$
$\sin at$	$\frac{\pi}{j} (\delta(\omega - a) - \delta(\omega + a))$
$\text{sgn}(t)$	$\frac{2}{j\omega}$
$\frac{1}{t}$	$-j\pi \text{sgn}(\omega)$
$e^{-\alpha t }, \alpha > 0$	$\frac{2\alpha}{\alpha^2 + \omega^2}$

Linearity:

$$\mathcal{F}\{f + g\} = \mathcal{F}\{f\} + \mathcal{F}\{g\}, \quad \mathcal{F}\{kf\} = k\mathcal{F}\{f\}.$$

Shift theorems: If $F(\omega)$ is the Fourier transform of $f(t)$

$$\mathcal{F}\{e^{jat} f(t)\} = F(\omega - a), \quad a \text{ constant.}$$

$$\mathcal{F}\{f(t - \alpha)\} = e^{-j\alpha\omega} F(\omega), \quad \alpha \text{ constant.}$$

Differentiation: The Fourier transform of the n th derivative, $f^{(n)}(t)$, is $(j\omega)^n F(\omega)$.

Duality: If $F(\omega)$ is the Fourier transform of $f(t)$ then

$$\text{the Fourier transform of } F(t) = 2\pi \times f(-\omega).$$

Convolution and correlation:

The Fourier transform of $f(t) * g(t)$ is $F(\omega)G(\omega)$ where

$$f(t) * g(t) = \int_{-\infty}^{\infty} f(\lambda)g(t - \lambda) d\lambda = g(t) * f(t).$$

The Fourier transform of $f(t) \star g(t)$ is $F(\omega)G(-\omega)$ where

$$f(t) \star g(t) = \int_{-\infty}^{\infty} f(\lambda)g(\lambda - t) d\lambda.$$



Discrete Fourier transform (dft)

Given a sequence of N terms

$$\{g[0], g[1], g[2], \dots, g[N - 1]\}$$

its discrete Fourier transform (dft) is the sequence

$$\{G[0], G[1], G[2], \dots, G[N - 1]\}$$

where

$$G[k] = \sum_{n=0}^{N-1} g[n] e^{-2jn k \pi / N}.$$

Further

$$g[n] = \frac{1}{N} \sum_{k=0}^{N-1} G[k] e^{2jn k \pi / N}.$$

Maclaurin & Taylor Series

Maclaurin Series:

$$f(x) = f(0) + \frac{x}{1!} f'(0) + \frac{x^2}{2!} f''(0) + \dots + \frac{x^r}{r!} f^{(r)}(0) + \dots$$

Taylor series (one variable):

$$f(x) = f(a) + \frac{(x - a)}{1!} f'(a) + \frac{(x - a)^2}{2!} f''(a) + \dots + \frac{(x - a)^r}{r!} f^{(r)}(a) + \dots$$

Taylor series (two variables): For a function $f(x, y)$ of two variables

$$f(x, y) = f(a, b) + \frac{1}{1!} \left((x - a) \frac{\partial}{\partial x} + (y - b) \frac{\partial}{\partial y} \right) f(a, b) + \frac{1}{2!} \left((x - a) \frac{\partial}{\partial x} + (y - b) \frac{\partial}{\partial y} \right)^2 f(a, b) + \dots + \frac{1}{r!} \left((x - a) \frac{\partial}{\partial x} + (y - b) \frac{\partial}{\partial y} \right)^r f(a, b) + \dots$$

Stationary points in two variables: For $z = f(x, y)$, stationary points (a, b) are located by solving $\frac{\partial f}{\partial x} = 0$

and $\frac{\partial f}{\partial y} = 0$. Define $\Delta = \frac{\partial^2 f}{\partial x^2} \frac{\partial^2 f}{\partial y^2} - \left(\frac{\partial^2 f}{\partial x \partial y} \right)^2$ at (a, b) .

The type of stationary point is given by:

$$\begin{aligned} \Delta < 0 & \quad \text{saddle point.} \\ \Delta > 0 \text{ and } \frac{\partial^2 f}{\partial x^2} > 0 & \quad \text{minimum point.} \\ \Delta > 0 \text{ and } \frac{\partial^2 f}{\partial x^2} < 0 & \quad \text{maximum point.} \end{aligned}$$

The Laplace transform

The Laplace transform of $f(t)$ is $F(s)$ defined by

$$F(s) = \mathcal{L}\{f(t)\} = \int_0^{\infty} e^{-st} f(t) dt.$$

function $f(t), t \geq 0$	Laplace transform $F(s)$
t^n	$\frac{n!}{s^{n+1}}$
e^{at}	$\frac{1}{s-a}$
$t^n e^{-at}$	$\frac{n!}{(s+a)^{n+1}}$
$\sin bt$	$\frac{b}{s^2+b^2}$
$\cos bt$	$\frac{s}{s^2+b^2}$
$\sinh bt$	$\frac{b}{s^2-b^2}$
$\cosh bt$	$\frac{s}{s^2-b^2}$
$t \sin bt$	$\frac{2bs}{(s^2+b^2)^2}$
$t \cos bt$	$\frac{s^2-b^2}{(s^2+b^2)^2}$
$u(t)$ unit step	$\frac{1}{s}$
$\delta(t)$ impulse function	1
$\delta(t-a)$	e^{-sa}
$f(t)$ periodic	$\frac{\int_0^T e^{-st} f(t) dt}{1-e^{-sT}}$
$t^n f(t)$	$(-1)^n \frac{d^n}{ds^n} F(s)$

Linearity:

$$\mathcal{L}\{f+g\} = \mathcal{L}\{f\} + \mathcal{L}\{g\}, \quad \mathcal{L}\{kf\} = k\mathcal{L}\{f\}.$$

Shift theorems: If $\mathcal{L}\{f(t)\} = F(s)$ then

$$\mathcal{L}\{e^{-at} f(t)\} = F(s+a).$$

$$\mathcal{L}\{u(t-d)f(t-d)\} = e^{-sd} F(s) \quad d > 0.$$

$u(t)$ is the unit step or Heaviside function.

Laplace transform of derivatives and integrals:

$$\mathcal{L}\{f'\} = sF(s) - f(0).$$

$$\mathcal{L}\{f''\} = s^2 F(s) - sf(0) - f'(0).$$

$$\mathcal{L}\left\{\int_0^t f(t) dt\right\} = \frac{1}{s} F(s).$$

The convolution theorem:

The Laplace transform of $f(t) * g(t)$ is $F(s)G(s)$ where

$$f(t) * g(t) = \int_0^t f(t-\lambda)g(\lambda) d\lambda = g(t) * f(t).$$

The z transform

Given a sequence, $f[k], k = 0, 1, 2, \dots$, the (one-sided) z transform of $f[k]$, is $F(z)$ defined by

$$F(z) = \mathcal{Z}\{f[k]\} = \sum_{k=0}^{\infty} f[k]z^{-k}.$$

sequence $f[k]$	z transform $F(z)$
$\delta[k] = \begin{cases} 1 & k=0 \\ 0 & k \neq 0 \end{cases}$	1
$u[k] = \begin{cases} 1 & k \geq 0 \\ 0 & k < 0 \end{cases}$	$\frac{z}{z-1}$
k	$\frac{z}{(z-1)^2}$
e^{-ak}	$\frac{z}{z-e^{-a}}$
a^k	$\frac{z}{z-a}$
ka^k	$\frac{az}{(z-a)^2}$
k^2	$\frac{z(z+1)}{(z-1)^3}$
$\sin ak$	$\frac{z \sin a}{z^2 - 2z \cos a + 1}$
$\cos ak$	$\frac{z(z - \cos a)}{z^2 - 2z \cos a + 1}$
$e^{-ak} \sin bk$	$\frac{ze^{-a} \sin b}{z^2 - 2ze^{-a} \cos b + e^{-2a}}$
$e^{-ak} \cos bk$	$\frac{z^2 - ze^{-a} \cos b}{z^2 - 2ze^{-a} \cos b + e^{-2a}}$
$e^{-bk} f[k]$	$F(e^b z)$
$kf[k]$	$-z \frac{d}{dz} F(z)$

Linearity: If $f[k]$ and $g[k]$ are two sequences and c is a constant

$$\mathcal{Z}\{f[k] + g[k]\} = \mathcal{Z}\{f[k]\} + \mathcal{Z}\{g[k]\}.$$

$$\mathcal{Z}\{cf[k]\} = c\mathcal{Z}\{f[k]\}.$$

First shift theorem:

$$\mathcal{Z}\{f[k+1]\} = zF(z) - zf[0].$$

$$\mathcal{Z}\{f[k+2]\} = z^2 F(z) - z^2 f[0] - zf[1].$$

Second shift theorem:

$$\mathcal{Z}\{f[k-i]u[k-i]\} = z^{-i} F(z), \quad i = 1, 2, 3, \dots$$

where $F(z)$ is the z transform of $f[k]$ and $u[k]$ is the unit step sequence.

Convolution: $\mathcal{Z}\{f[k] * g[k]\} = F(z)G(z)$.

where

$$f[k] * g[k] = \sum_{m=0}^k f[m]g[k-m].$$

Numerical Integration

Simpson's rule: for n even, and $h = \frac{x_n - x_0}{n}$,

$$\int_{x_0}^{x_n} f(x) dx \approx \frac{h}{3} (f_0 + 4f_1 + 2f_2 + 4f_3 + \dots + 2f_{n-2} + 4f_{n-1} + f_n).$$

Truncation error $\approx -\frac{(x_n - x_0)h^4 f^{(4)}(\xi)}{180}$.

n point **Gauss-Legendre** formula:

$$\int_{-1}^1 f(x) dx \approx \sum_{i=1}^n w_i f(x_i).$$

n	x_i	w_i
2	± 0.577350	1.000000
3	± 0.774597	0.555556
	0.0	0.888889
4	± 0.861136	0.347855
	± 0.339981	0.652145
5	± 0.906180	0.236927
	0.0	0.568889
	± 0.538469	0.478629

Ordinary differential equations

To solve $\frac{dy}{dx} = f(x, y)$:

Euler's method:

$$y_{r+1} = y_r + hf(x_r, y_r).$$

Modified Euler method:

$$y_{r+1}^{(p)} = y_r + hf_r \quad f_{r+1}^{(p)} = f(x_{r+1}, y_{r+1}^{(p)}).$$

$$y_{r+1}^{(c)} = y_r + \frac{h}{2}(f_r + f_{r+1}^{(p)}).$$

Runge-Kutta method:

$$k_1 = hf(x_r, y_r), \quad k_2 = hf\left(x_r + \frac{h}{2}, y_r + \frac{k_1}{2}\right).$$

$$k_3 = hf\left(x_r + \frac{h}{2}, y_r + \frac{k_2}{2}\right), \quad k_4 = hf(x_r + h, y_r + k_3).$$

$$y_{r+1} = y_r + \frac{1}{6}(k_1 + 2k_2 + 2k_3 + k_4).$$

